

Micasa



AIR FRYER

**Instruction Manual
Models MA0256AF**

**Read in full and retain for future use
Keep this manual with the appliance. If the appliance is to be used by a third
party, this instruction manual must be supplied with it.**

Micasa

MICASA branded product provides an affordable range of well presented, elegant home ware and appliances. Products which are ranged and selected are chosen to suit your contemporary lifestyle and cater for your home ware needs today. Micasa aims to provide products which are fashionable, affordable, and reliable to meet your home ware demands.

MICASA will provide value for money products to make every day home life more enjoyable and convenient.

The **MICASA** range of products is continually developing and new products will be introduced with expansion of the range. So keep in touch for further news on new products in the future.

We hope you enjoy your experience with **MICASA**

Contact enquiry@micasa-appliances.com

Visit www.micasa-appliances.com

Helpline

New Zealand call toll free 0508-274-2722

Australia call +64-9-974-9206

Distributed by

Asia Pacific Brands Limited

PO Box 113001 Broadway

Newmarket, 1149

Auckland, New Zealand

FEATURES

- ✓ 1500 Watt Class1 appliance
- ✓ Thermostat Control
- ✓ 30 Minute timer
- ✓ Power ON indicator lamp
- ✓ Power and temperature indicator light
- ✓ Overheat protection
- ✓ Cool-touch housing and handle

A new healthier way to cook your favourite foods. No need to deep fry anymore. Most foods do not require oils at all. The air fryer uses hot air circulated by high speed fan and heat from an overhead grill element.

PARTS DETAILS

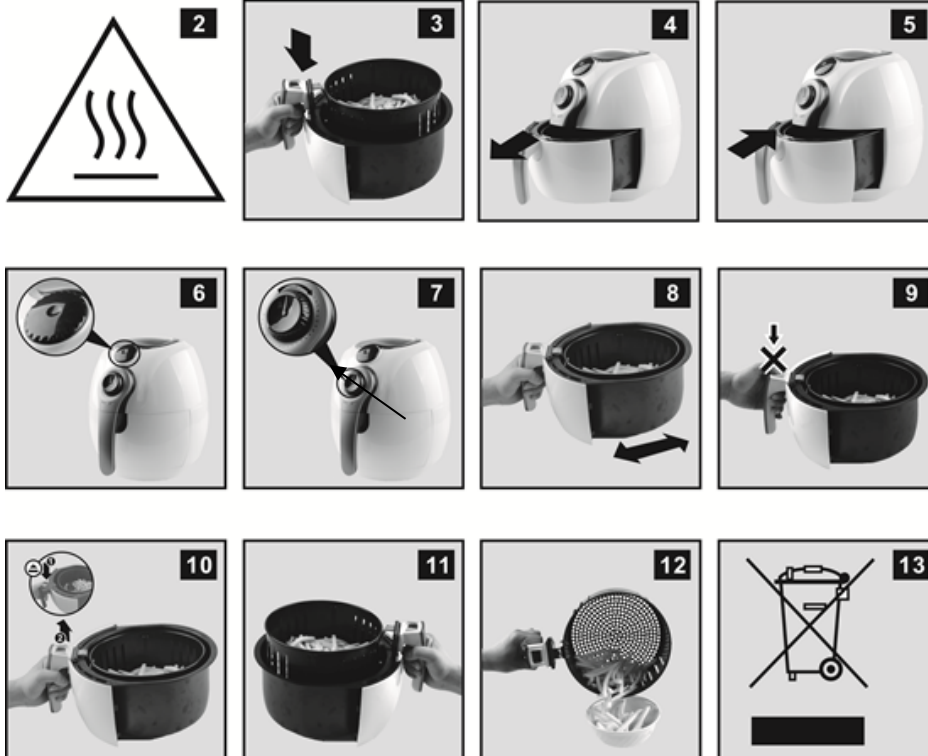
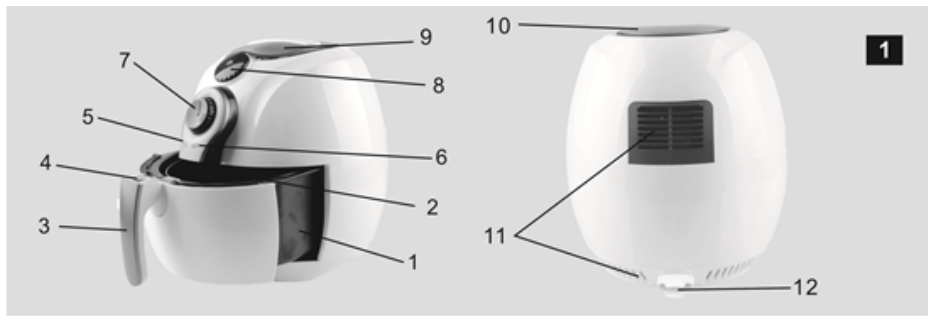

- | | |
|----------------------------------|----------------------------------|
| 1. Cooking basket | 7. Timer control (0-30minutes) |
| 2. Cooking pan assembly | 8. Temperature control 80-200 °C |
| 3. Cook assembly handle | 9. Handle |
| 4. Cooking basket release button | 10. Air inlet |
| 5. Heat cycle ON indicator | 11. Air outlet |
| 6. Power On indicator | 12. Supply cord entry |

BEFORE FIRST USE

Before first use remove any stickers or similar from the appliance except for the rating label. Dispose of any plastic bags as they pose a risk to young children of suffocation.

Wash the cooking basket and cooking accessories. Wash in hot soapy water, dry with a dry towel.

OPERATION

Note. Appliance will not operate unless the cooking pan assembly is fitted correctly.

- Prepare the food item to be cooked
- Place the appliance on a heat resistant level surface away from combustible materials. Allow a gap, do not block air vents. Air vents are located on the rear and around the top.
- Connect the supply plug to a suitably earthed 230-240V ~ 50Hz outlet. This appliance is designed to work in New Zealand and Australia safely.
- Remove the cooking pan assembly by pulling outwards
- Place food items into the cooking basket and place into the cooking pan assembly. Do not overfill the cooking basket. This will affect the cooking abilities.
- Place the cooking pan assembly into the cooking chamber.
- Once connected to the power supply the POWER ON light will illuminate
- Select the desired heat setting on the thermostat control knob.
- Select the desired cooking time on the timer.
- The heating indicator will glow when the heat cycle is on. When the lamp goes off the selected temperature has been reached.
- At the completion of the cooking time carefully remove the cooking pan assembly and serve.

Warning! Do not use without the cooking basket.

Warning! Do not touch hot metal surfaces. Use the handles.

COOKING GUIDE

A new healthier way to cook your favourite foods. No need to deep fry anymore. Most foods do not require oils at all. The air fryer uses hot air circulated by high speed fan and heat from an overhead grill element.

Tips

1. When cooking large quantities smaller sized ingredients are best producing a shorter cooking time and more consistent finished product.
2. Do not over fill the baskets. Overfilling the basket with food will lengthen the cooking time and effect the air circulation, hindering consistent cooking.
3. When cooking items such as fries shake the basket once or twice during cooking. This ensures even cooking
4. Warning! Do not place oils into the cooking bowls. Apply oils, cooking sprays to food item if required pre-cooking. There is no need to cook with oils in the pan. Apply a small amount to the bottom of basket if required to stop food sticking only.
5. If there is a large amount of smoke remove the cooking pan assembly and drain excess oils that may have occurred. If using foods that are high in fat reduce the amount in the basket.
6. When first using always undercook until you are familiar with the appliance.

Times are a guide only dependent on size and freshness of food choice. If cooking from cold it is recommended to add 2-3 minutes to the cooking time also or alternatively pre-heat the appliance before cooking by heating for 2-3 minutes.

Warning! Handle hot surfaces with care use heat protectant gloves or similar.

Food Item	Min – Max grams	Time (min)	Temperature °C	Mid cooking option	Notes
Fries (thin cut)	300-700	9-16	200	Remove and shake basket	
Fries (thick cut)	300-700	11-20	200	Remove and shake basket	
Fries (homemade)	300-800	16-20	200	Remove and shake basket	Add ½ teaspoon oil
Potato Wedges	300-800	18-22	180	Remove and shake basket	Add ½ teaspoon oil
Steak	200-500	8-12	180		
Chops	200-500	10-14	180		
Drumsticks	200-500	18-20	180		
Chicken breast	200-500	10-15	180		
Cake	300	20-25	160		Use baking tin
Muffin	300	15-18	200		Use baking tin

RECIPE SUGGESTIONS

Crumbed chicken

You need

2-3 tablespoons of vegetable oil or butter

100g of bread crumbs

1 egg

8 chicken pc

To cook

Preheat air fryer to 180°C

Mix the oil and breadcrumbs together thoroughly in a bowl

Whisk the egg mix in a separate bowl

Dip the chicken pieces into the egg mix

Dip the chicken into the breadcrumb mix and evenly coat

Place chicken pieces into cooking basket and place into air fryer

Cook for 12-14 minutes at 180°C.

Beef Schnitzel

You need

2 tablespoons vegetable oil
50g breadcrumbs
1 egg
1 large thin beef schnitzel
Serve with sliced lemon

To cook

Pre-heat air fryer to 180°C
Mix the bread crumbs and oil together thoroughly in a bowl
Whisk the egg in a separate bowl
Dip the schnitzel into the egg mix
Coat in breadcrumbs evenly
Cook in air fryer for 10-12 minutes at 180°C

Homemade fries

You need

2 large potatoes
1 tablespoon vegetable oil
Sea salt to taste

To cook

Peel the potatoes and cut into even slices (size to suit). Keep as regular as possible across the potatoes. Soak for 15-20 minutes then pat dry.
Place the fries into a bowl (or bag) and add the vegetable oil. Mix together so that the fries receive a thin coating of oil
Place into air fryer and cook for 20 minutes on 200°C
Shake basket half way thru cooking cycle

Crumbed Fish

You need

4 tablespoons vegetable oil
100g breadcrumbs
1 egg
4 fish fillets of choice
1 lemon

To cook

Preheat oven to 180°C
Mix vegetable oil and breadcrumbs thoroughly
Whisk the egg in a bowl
Dip fish fillets into egg mixture
Coat fillets with breadcrumb mix
Place fillets into basket and cook for 10-12 minutes

Banana Cake

You need

50g butter
1/3 cup brown sugar
1 egg
1 large mashed banana
2 tablespoons of honey
1 cup self-rising flour
½ teaspoon of cinnamon
Salt to taste (if required)
Cooking spray
Oven proof cake tin that will fit into basket (not supplied)

To cook

Preheat air fryer to 160°C
Spray the cake baking tin insides with a small coating of cooking spray
In a large bowl beat the butter and brown sugar until smooth and creamy.
Add the egg, banana, honey, cinnamon, salt (if required), flour and whisk until mixture is smooth.
Place into cake bake dish.
Place into air fryer and cook for 30 minutes on 160°C.
Insert a toothpick into the cake to test. When it is removed clean the cake should be cooked.

Chocolate Cake

You need

50g caster sugar
50g butter
1 tablespoon apricot jam (or similar)
50g plain flour
1 Egg
1 tablespoon cocoa
Salt to taste
Icing sugar
Oven proof cake tin that will fit into basket (not supplied)

To Cook

Pre heat air fryer to 160°C
Spray a thin layer of cooking spray onto the cake tin
In a large bowl beat sugar and softened butter until creamy.
Add the jam and whisked egg
Sift flour, cocoa and salt into mix and stir thoroughly
Place into cake tin and level
Bake for 15 minutes at 160°C
When a toothpick can be inserted and removed clean the cake should be cooked properly.
Serve dusted with icing sugar.

CLEANING GUIDE

Warning! Disconnect from the power supply before cleaning.

Warning! Allow to cool before cleaning.

Warning! Do not place in a dishwasher.

Step 1. Remove the cooking pan assembly.

Remove the cooking basket and wash in hot soapy water, dry with a dry towel.

Wash the cooking pan assembly in hot soapy water, dry with a dry towel.

Step 2. Carefully wipe with a damp cloth any residual spillages from inside the appliance.

Step 3. Wipe the outer surface of the appliance with a soft damp cloth, dry with a dry towel.

Warning! Do not immerse the appliance in liquids Do not use with wet hands or use in damp situations.

Warning! Do not use harsh chemicals, wire wool or scouring pads to clean the cooking surface. This will damage the non-stick cooking surface.

SAFETY

To avoid any risk of risk of fire, shock hazard or personal injury, follow these guidelines.



Warning! When not in use or before cleaning, always disconnect the appliance from the mains supply



Warning! The temperature of accessible surfaces may be high when the appliance is operating.

Warning! Do not splash with liquids. Do not allow the appliance supply plug and cord to get wet or be immersed in any liquid.

Warning! Disconnect from the mains supply and switch off when not in use.

Warning! In order to avoid overheating, do not cover the appliance.

Warning! Do not use this appliance if it has been dropped or damaged in any way, or if the supply cord is damaged.



Warning! Children

This appliance is not intended for use by persons (including children) with reduced physical, sensory or mental capabilities, or lack of knowledge, unless they have been given supervision or instruction concerning safe use of the appliance by a person responsible for their safety. Young children must be supervised to ensure that they do not play with the appliance.

Warning! Safely dispose of any plastic bags or other packaging that may present a hazard to young children of suffocation or choke hazard.

Warning! For household indoor use only, do not use outdoors. Not for commercial use.

Warning! Do not abuse or damage the supply cord. If for any reason the cord is damaged, it must be replaced by the manufacturer, its service agent or a similarly qualified person in order to avoid hazard. A replaceable cord must be replaced with an authorised replacement from an authorized service agent.

Warning! When cleaning or putting the Air Fryer away, switch off the appliance and always pull out the plug from the socket (pull on the plug, not the cable)

Warning! This appliance must only be used with a genuine replacement cord set marked with the same markings as the one supplied

Warning! Keep the appliance and supply cord away from other heat sources.

Warning! Do not allow the supply cord to hang over the edge of any table. Young children may pull the appliance of causing a risk of burns, shock or fire hazard.

Warning! This appliance must not be mounted or located below or directly in front of a socket outlet.

Warning! The appliance must not be used if the appliance is damaged.

Warning! Do not leave this appliance unattended while in use. This appliance must not be used by means of an external timer or separate remote-control system.

Warning! Do not allow the appliance to come into contact with curtains, walls, clothing, dishcloths or other flammable materials.

Use

This appliance is intended to be used in household and similar applications such as:

- Staff kitchen areas in shops, offices and other working environments;
- Farm houses
- By clients in hotels, motels and other residential type environments;
- Bed and breakfast type environments

Warning! Do not place the appliance on a gas or electric burner, or inside an oven or any other heat source.

Warning! Do not tip over.

Warning! Do not move when in operation.

Warning! Do not cover this appliance.

Warning! Fire risk exists if any appliance is covered by or positioned near curtains or other combustible materials

Smoke. During first use there may be a small amount of smoke, this is normal. This is only the oils used in production to protect the heating elements from rust being burned off from the hot element.

Warning! Heat. Always use on a flat stable heat resistant surface.

Warning! High temperatures. Metal components will reach very high temperatures in use. Always handle with care, use oven gloves or similar when handling. Allow to cool before store.

Warning! Hot steam. May be expelled when opening. During cooking process hot steam will be expelled through the air vents. Keep hands and face away.

Warning! Air vents! Do not place any object onto the top. Do not block the rear air vents. Keep a gap around the appliance of at least 10cm.

WARRANTY

Retain your receipt as proof of purchase.

If for any reason the appliance does not function correctly or shows signs of damage please stop using immediately and return it immediately to the retailer.

This product is covered by a 12 month warranty by Harvey Norman (NZ) PTY Ltd. This warranty does not exclude any obligations to the consumer covered by the NZ Consumers guarantee act.